



THE THEORY OF DRIVING A MOTOR

EVERYTHING YOU SHOULD
KNOW TO BE A SAFE ROAD USER

e-theory.nl
Burchtlaan 30
2242 GJ Wassenaar
info@e-theory.nl
Author: B.N. van de Ruit.



TABLE OF CONTENTS

1 INTRODUCTION

1.1 Driving a motor and fear

2 THE BASICS OF DRIVING A MOTOR

2.1 Controlling a vehicle

2.2 Driving away

2.3 The steps of driving a motor

2.4 Balancing

2.5 Alcohol

3 GENERAL SAFETY AND SAFETY TERMS

3.1 Safety

3.2 Safety terms

3.3 Rules by importance

3.4 Position on the road

3.5 Position on the road at a roundabouts

4 SPEED

4.1 Speed limits on different roads

4.2 Maximum speeds for different vehicles

5 JUNCTIONS

5.1 Priority rules

5.2 The rules of turning off

5.3 Techniques of watching the road

6 ROUNDABOUTS

7 SPECIAL MANOEUVRES

8 OVERTAKING

9 BEING STATIONARY

10 PARKING

11 TRUCK ROADS AND MOTORWAYS

11.1 Joining and exiting traffic

12 LIGHTS

13 GENERAL ATTENTION POINTS

13.1 Road markings (on the road surface)

13.2 Pedestrian crossing

13.3 Bus stops

13.4 Tunnel

13.5 Seatbelts

13.6 Loads

13.7 Dike roads

13.8 Aquaplaning

13.9 Danger of skidding.

13.10 Facts

14 ENVIRONMENTAL ASPECTS

15 CRIMES

16. DANGEROUS SITUATIONS

17 THE DUTCH TRAFFIC SIGNS

17.1 Traffic directions

Special thanks to: M. de Bruijn, J. de Bruijn, T. Juffermans,
F. Graafland, N. Lamfers; editing, D. Orlov; russisch,
E. van der Sman; italiaans en K. Maes; frans.

Design: Karin van den Broek, www.studiohartje.nl

Wij hebben grote zorg besteed aan het samenstellen van deze uitgave. De schrijver, de redactie en de uitgever zijn zich ervan bewust dat fouten en onvolkomenheden kunnen zijn ontstaan. De schrijver, redactie en uitgever kunnen hiervoor geen aansprakelijkheid aanvaarden.

De teksten uit alle door ons ontwikkelde uitgaven zijn auteursrechtelijk beschermd. Alle teksten, vormgeving, beeldmerken en logo's hieromtrent zijn gedeponeerd bij de notaris.

1. INTRODUCTION

The theory of driving a motor is that which you should know to be a safe road user.

In this book you will learn the main rules of the Dutch traffic laws as our basic principles. An example of one of these laws is that everybody must drive as far to the right on the road as is possible. But while overtaking, it's not possible to drive on the right side on the road. For these situations sub-rules are made. These rules can be found in the official regulations of traffic rules and signs. Of course there are some exceptions such as a tram, which cannot drive on the right side on the road.

The advantage of knowing the main rules is that when you know these basics, you can apply them to every situation. For example after overtaking another motor, you know you have to move back to the right-hand side of the lane. When you know the main rules, this is something you can come up with yourself.

This brings us back to the goal of this book: Learning to be a safe driver! Not simply teaching you all the rules. Stopping for a cyclist at a junction who has right of way, is something you do when you know the rules. When a safe road user would already have seen the cyclist, slowed down ahead and let the cyclist pass the junction before they arrived so they won't have to stop. This is an important difference.

This book will look at sub rules and exceptions to the rules, but a lot will be left to your own insights. Extra attention will be paid to the routine of driving a motor, from the moment you get in to every single situation on the road.

This book is not just for starting drivers who have to pass their theory-exam, but also for the more experienced driver who wants to refresh their memory. It's also suitable as a reference book in unclear traffic situations. As you will see, we have used lots of pictures. Because of this, this book is also suitable for people with dyslexia.

The author of this book, Bas van de Ruit, has been an active driving instructor since 1980. As the first driving school owner in Holland, he received the symbol of quality (SKR) from the minister of Transport, Public Works and Water Management. Next to his work as a driving instructor, Bas is also qualified as a KGI motorbike instructor by the KNMV, who is constantly working on improving the quality of driving lessons in Holland.

1.1 Driving a motor and fear.

Whenever you get into a motor, you are going to have to deal with fear. This can either be fear of driving itself or fear for a certain situation you get into.

But this is not necessarily a bad thing. It's very good to realise that driving a motor involves certain risks. This realisation helps you to take responsibility for your actions. It will also show you that only qualified, healthy people should be on the road.

The thing you have to know about fear is that people who are afraid, just like animals, have the tendency to look down. This is logical because by doing so you protect your eyes in dangerous situations. But when driving a motor this becomes a big problem, because people have the tendency **to steer towards what they are looking at**. So looking down because of fear, will make you drive incoherently. You also won't be as attentive to other traffic around you as you should be. So make sure you're not watching that one tree on the side of the road but look into the corner.

To become a safe driver you have to overcome your fear and keep looking far ahead to what you are driving towards. Look as if you're opening a Chinese fan and widen your view as far as possible, don't just look at the road. Things on the side of the road, like sidewalks and streetlights, can help you determine whether or not you're approaching a junction and can help you to anticipate the situation.

When you know you're in control of your vehicle and you know the rules, then you'll realise that there's no reason to be afraid. If you don't have this confidence, it's good to take some (more) driving lessons.

- a This motorcyclist is a good example of someone who's watching where he's going



2. THE BASICS OF DRIVING A MOTOR

2.1 Controlling a vehicle

Driving a vehicle demands a lot from a person. First of all you have to learn to control the vehicle: steering, braking and the proper looking techniques. Only when you're experienced with these things, can you begin to work on your safety on the road.

2.2 Driving away

Before you get into the motor, you already should be aware and watching all the things that can influence your driving and other traffic. First of all you should observe the **weather**. Things as danger of sliding, strong wind or rain are things you have to take into account when driving and can even cause you decide against drive at all. Also the **time of day** is important. For example if you depart during rush hour, there'll be more traffic so it will take longer. Then it would be wiser to leave earlier so you don't have to rush and be in danger.

2.3 The steps of driving a motor

The process of driving a motor can be divided in the following steps:

- Observing *With whom or what am I going to deal?*
- Predicting *What will the other road users do?*
Traffic rules
- Evaluating *What do I have to do?*
Who has right of way?
Traffic rules
- Deciding *I have to break/accelerate/steer!*
- Acting *Doing what you have decided*

Observing: I'm approaching a junction and see another motor approaching from a side street.

Predicting: I see that he is approaching with considerable speed without his indicators on, so I can assume he's going to straight on. I know he has right of way because he's coming from the right on an equal junction.

Evaluating: I estimate my distance to the junction and my own speed.

Deciding: I have to break and give the other motor right of way.

Acting: I break.

Half the work of driving successfully depends on your knowledge of the traffic rules. The less time you have to think about it, the more attention you can pay to the road and other road users.

The other half is determined by your physical condition when you enter your motor. This can be influenced by the following factors:

- Fatigue.
- Tension or stress.
- Emotions.
- Physical fitness.
- Alcohol or drugs.
- Use of medicine.
- Wrong estimations of your own abilities (often with younger people).

2.4 balancing

- a. straight
- b. leaning with the motor
- c. leaning against the motor

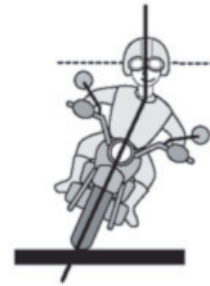
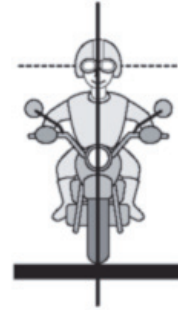

2.5 Alcohol

Alcohol numbs your brain. Therefore your ability to drive will go downhill. Your reaction speed is reduced, you won't be able to see the colour red as well as usual and the adjustment speed of your eyes to different lights is also reduced. Alcohol also causes tunnel vision. You won't be able to see what happens at the side of the road so you will not see cyclists and traffic coming the right or left.

In other words, all the benefits of drinking in a bar are negatives when you're driving.

The amount of alcohol is the same per glass: a glass of wine has the same amount of alcohol as a glass of beer.

From January the 1st 2006 as a starting driver you are allowed to have **0,2 promille** of alcohol in your blood or **88 ugl.** in your breath. That's three quarters of a glass of alcohol.

After 5 years of owning your license you can have **0,5 promille** or **220 ugl.**

After consuming too much alcohol you're not allowed to drive a vehicle. This means you're not even allowed to drive a bicycle. You can even lose your license for cycling with too much alcohol in your blood. For those who are very attentive: You are allowed to sit on a horse after consuming too much alcohol, because a horse is not a vehicle.

- a The amount of alcohol is the same per glass: a glass of wine has the same amount of alcohol as a glass of beer



3. GENERAL SAFETY AND SAFETY TERMS

3.1 Safety

Art. I of the Traffic law WVV:

Goal of the Traffic Laws: Safety on the road and maintaining the environment and mobility

All these rules are there for your safety and that of others. That's why it is so important you know them and use them.

Art. 5 of the Traffic law

It is forbidden for everyone to act in a fashion that causes danger or could cause danger on the road or hinder or could hinder other traffic.

This means, among other things:

- You're not allowed to make unnecessary noise (for example a loud exhaust).
- You're not allowed to drive with things that impede your vision like broken or dirty mirrors or visor.
- You're supposed to adapt your speed to the situation. So don't drive too slow on the highway, where everybody else is driving fast. But don't drive at a high speed through small streets, where children could be playing.

This article of the traffic law **applies to all**. This also means you're not allowed to do things that can be dangerous to the traffic even when you yourself are not participating. For example you're not allowed to throw little stones at drivers or make a fire with so much smoke it could hinder traffic.

- a. You are not allowed to drive with three persons on a bike



3.2 Safety terms

Art. 2 of Regulation Traffic Rules and Traffic Signs RVV: *Terms of traffic*

To understand and apply the rules of traffic, you have to be familiar with terms, like: what is the road or what is a driver? So, drivers who come from the right have right of way to all the other traffic, but is a pedestrian with a bicycle in his hand a driver or not?

The road: The entire road, including the banks, banks in the middle and the pavement. So: from house to house, from garden to garden.

Traffic: All road users.

Road user: All people on the road. They can be divided into pedestrians and drivers.

Pedestrians: All people moving on foot, including roller-skaters. It's also possible for pedestrians to have something in their hands like a wheelbarrow, a pet or a baby buggy. If you're walking with a bicycle, moped or motorbike, you have to follow the rules of pedestrians. With a motorbike you don't have to wear a helmet but you do have to have your drivers license for motorcycles

a. The girl with her dog is a pedestrian
b&c These people with the horse and the sheep are drivers not pedestrians



- Driver: All road users except pedestrians.
- Motorised vehicles: All motorised vehicles, except mopeds and vehicles for disabled people. If the vehicle needs to use rails, it isn't a motorised vehicle.
- Motorbike: Motor vehicle on two wheels, with or without sidemotor or trailer.
- Moped: A vehicle which has two or three wheels with a combustion engine or an electric motor. Mopeds can not be driven faster than 25 km/h because of its construction.
- Priority vehicle: All motor vehicles using blue rotating / flashing lights and a two or three- tone siren. These are usually police motors and police motorbikes, fire engines or ambulances.
- Lorry: Motor vehicle not equipped for the transport of people, with a permitted maximum mass of more than 3500 kg.
- Bus: Motor vehicle, equipped for transport of more than 8 persons, which follows a strict time schedule and is used for public transport.
- a. Taking the Cat to the vet like this, is that permitted?



3.3 Signals ranked by important

There are traffic lights, traffic signs, traffic rules and instructions of the authority. Which of these is the most important?

- 1 Instructions by authoritative figures. If a police officer gives a driver a sign, he needs to follow this sign, even if it means driving through red light.
- 2 Traffic lights. If an arrow of the traffic light is green, you have right way.
- 3 Traffic signs. Although a tram usually has right of way, a traffic sign indicating that you are on a priority road, gives you right of way over a tram coming from the left or right.
- 4 Traffic rules.

3.4 Position on the road

Art. 3 RVV

Drivers need to drive on the most right lane.

All drivers need to stay on the most right lane of the road. A maximum of two cyclists are allowed to cycle side by side. This is not allowed for mopeds.

Driving on the left lane is only permitted if:

- a Position on the road.
- b Position on the road.
- c The driver needs to sort to the left of if the driver needs to overtake another motor or car

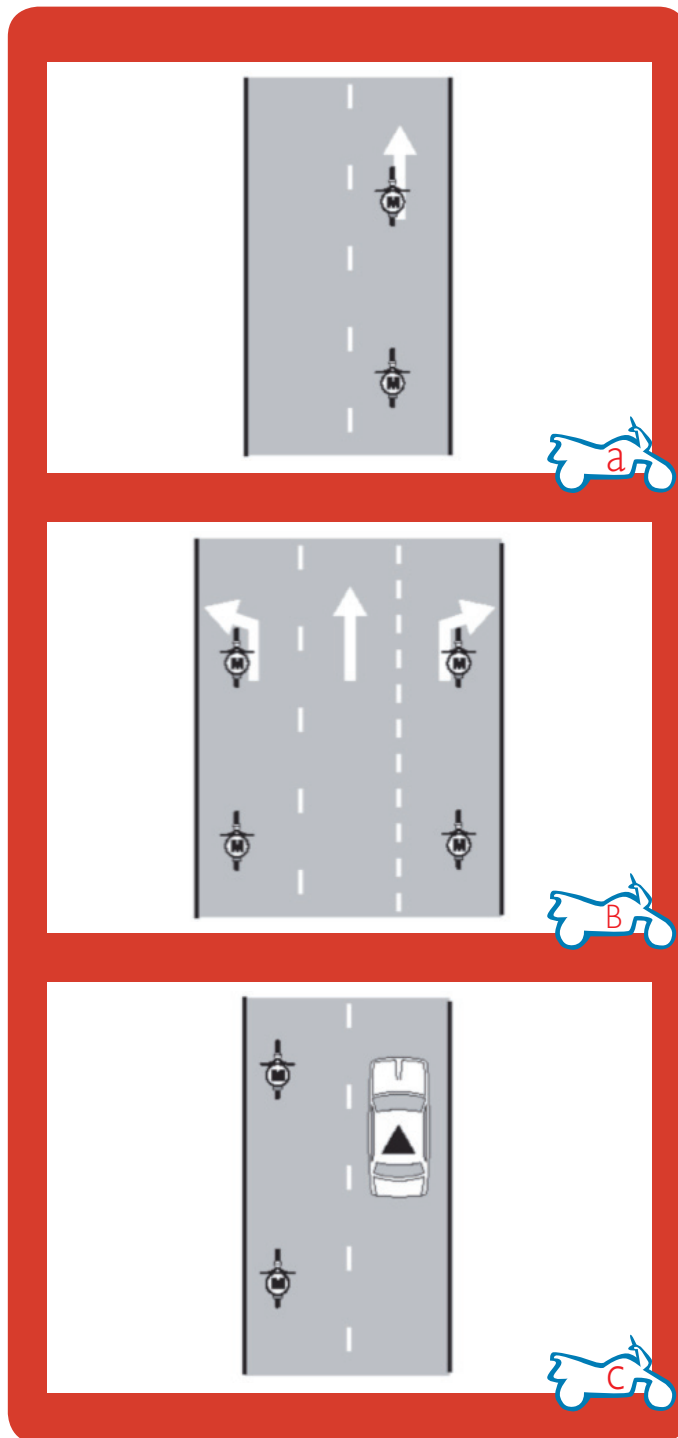

3.5 Position on the road at a roundabouts

- a Position on the road turning left.
- b Position on the road turning right.
- c Position on the road going straight on.

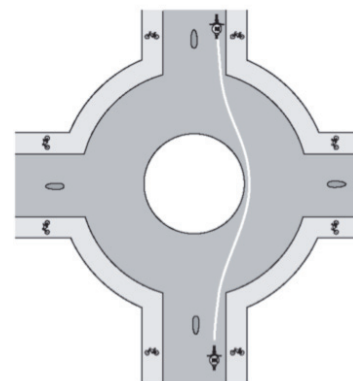
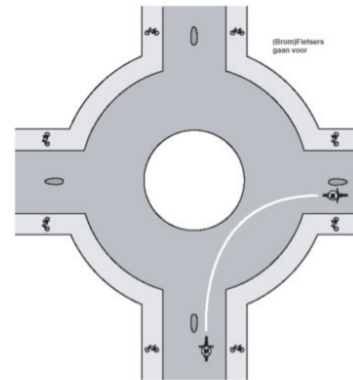
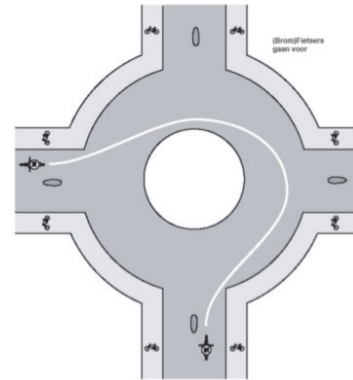

4. SPEED

Art. 19 RVV

The driver must be able to stop the vehicle within a distance that allows him to keep a clear view of the road and that the road is available.

Stopping distance = reaction distance + braking distance

So the stopping distance will be determined by the reaction time and this can be influenced by the condition of the driver. (See chapter 2)

But it can also be influenced by:

- The road surface (tarmac, a new surface, grit)
- The weather (slippery).
- The quality of your brakes.
- The quality of your motor tires and shock absorbing suspension.

Your speed needs to be low enough that so you will be able to stop your vehicle when you should, for example, to give someone right of way or in potentially dangerous situations such as children crossing the street unexpectedly. Speed limits differ per road, but the general rule is that you need to drive your vehicle so slow enough that you can stop if necessary. You are allowed to drive 30 km/h in a residential area, but sometimes it isn't possible to drive faster than 20 km/h because of the many parked motors and narrow roads. The speed limits are a regulation but you need to stay focussed and act wisely in situations where you can not drive at the maximum speed.



4.1 Maximum speed limits on different roads

- In a pedestrian or residential area: slowly like 15 km per hour.
- In a 30 km/h zone: 30 km per hour.
- Within the built-up area: 50 km per hour.
- Outside the built-up area: 80 km per hour.
- On truck roads: 100 km per hour.
- On motorways: 120 km per hour.

4.2 Maximum speed of vehicles

- Micro motor: 45 km/hour.
- Motor-assisted bicycle: 25 km/hour.
- Moped: 30 km/hour on a bicycle/moped path within the built-up area.
- 40 Km/hour on the road within the built-up area.
- 40 Km/hour outside the built-up area.
- Motorbikes with a sidemotor are allowed to drive on the motorway with a speed limit of 120 km per hour.
- Motor vehicles with trailers are allowed to drive on the motorway with a speed no greater than 90 km per hour.
- A lorry is not allowed to drive on the motorway with a speed greater than 80 km/hour.

The roads outside the built-up area are marked with lines in a special manner. The advantage of this is that you can see what the speed limits are by looking at the road.

- a. 60 km/hour
- b. 80 km/hour
- c. 100 km/hour



5. JUNCTIONS

If road users are driving towards a junction at the same time, they need to follow the traffic rules, traffic signs or the traffic lights. On a junction, you need to follow two kinds of rules depending on where the other road users/drivers are coming from:

1. Priority rules. (a)

You use these rules if the other person is coming from the right or the left. These rules only apply to drivers. So this means that pedestrians do not get right of way on a crossing road.

2. Rules of turning off.

You need to use these rules if the other person is driving on the same road as you. The rules of turning off apply to all road users. Pedestrians who are using the same road as you are, have right of way.

b. This pedestrian walks on the same road as the vehicle. He gets right of way of the motor

Important to know is that which of these two rules is applicable to you. You have to ask yourself the question:

Where is the other person come from? Which direction is he/she going, is not important unless you are on the same road as a other person and both want to turn off the same direction (see chapter 5.2)

If the other person is coming from another road on your left or right-hand side, then you use the priority rules. Is the other person using the same road as you, then you must use the rules of turning off.



5.1 Priority rules

Art. 15 RVV

On junctions, drivers give right of way to all drivers who are coming from the right.

So:

1. Priority rules are only used at **junctions**.
2. Priority rules only apply to **drivers** of vehicles.
3. You only use priority rules if the **other person** is on the **other road**.

Give right of way =

you need to give the other driver right of way on the junction. (must not hinder the other driver)

You are not allowed to block the junction. Only cross the junction if you know you will not have to stop.

You may hinder the **tram**. This means that you can sort on a tram lane and stand still if there is no tram coming.

Outside the built-up area, the traffic signs are **beyond** a junction. Within the built-up area, the traffic signs are **in front** of a junction.

- a. On an unmarked junction all drivers coming from the right have right of way
- b. The motorbike gets right of way over the tram because he drives on a priority road



Exceptions:

1. If you are driving on a junction or priority road you get right of way from all other road users.
2. Drivers on hardened road surfaces should have right of way over drivers on unhardened road surfaces.
3. On an unmarked junction, trams have right of way over all drivers.
4. **The police, fire brigade and ambulances** with flashing lights and siren have right of way over all road users.

Give right of way to all drivers who are using the priority road:

- a The man in red is a pedestrian, so he does not get right of way over the vehicle
- b The children with the sheep count as drivers so they get right of way over the vehicle
- c The child with sheep comes from the right, so the motor must give way to the chills

Note: If you leave a priority road or junction that bends, you will get right of way over all the drivers who are on or want to make use of the junction or road.



5.2 The rules of turning off

Art. 18 RVV

Drivers, who want to turn off, must give right of way to all other traffic which is using the same road and want to continue on the same road.

In other words:

1. **Straight ahead** on the same road gets right of way.
2. The rules of turning off apply to all road users.

Expectations:

1. A tram that wants to turn off gets right of way over all the road users who are using the same road. So the priority rules do not apply to this situation.

Note: If two drivers are using the same road and they want to use the entrance the same road, than the driver with the shortest bend gets right of way(turn off to the right) over the longest bend(turn off to the left).

- a. The drivers who are using the priority road (the thick black mark on the sign) get right of way over all the road users
- b. The grey vehicle needs to give right of way to the tram which is using the same road. The driver needs to stop before the crossing
- c. The moped needs to give way to the tram that is using the same road



5.3 Techniques of watching the road

You need to drive in a way that makes you able to stop in every situation. If the road is clear, you can go!

- a. Techniques of watching the road if your driving straight ahead

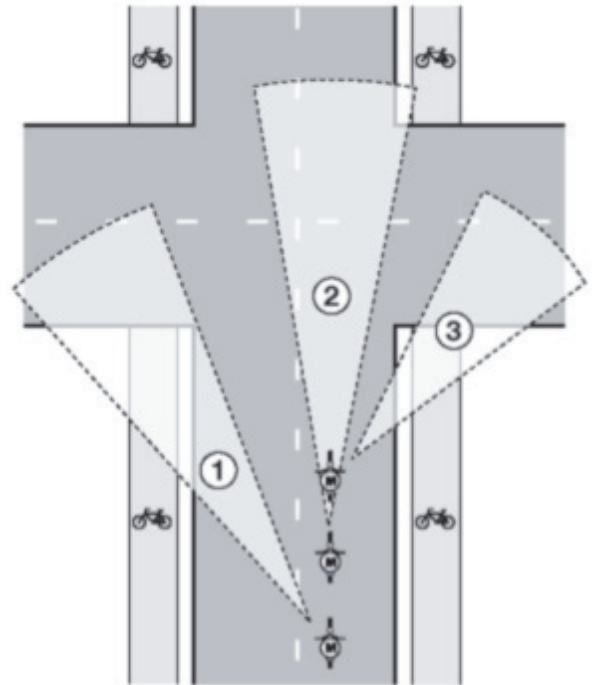

You need to drive in a way that makes you able to stop in every situation. If the road is clear, you can go!

- a. Techniques of watching the road if your driving straight ahead

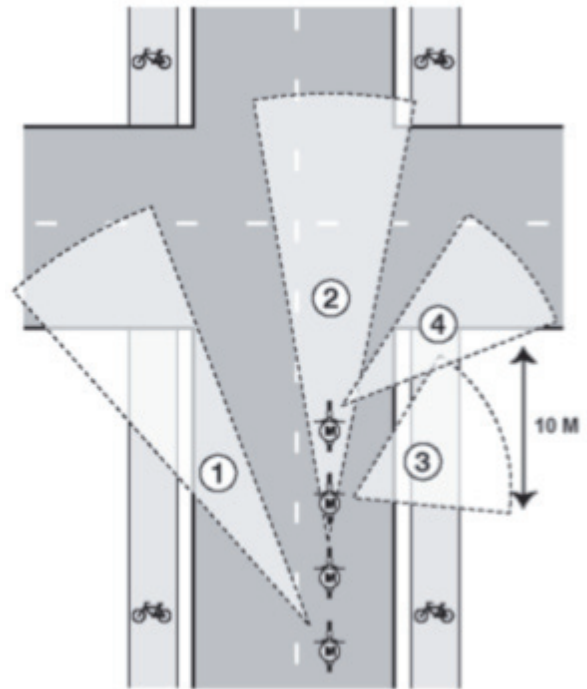

You need to drive in a way that makes you able to stop in every situation. If the road is clear, you can go!

- a. Techniques of watching the road if your turning left

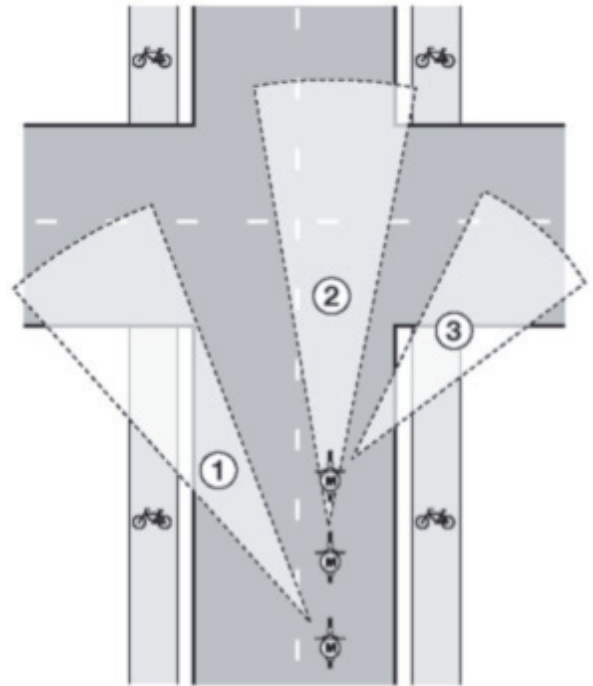

6. ROUNDABOUTS

The road leading up to the roundabout always has the sign D5. There are no special rules for using roundabouts; a roundabout is a junction so you have to follow the priority rules.

There are two kinds of roundabouts:

1. Priority roundabouts:
These are the most common. If you are approaching a priority roundabout, you will see sign D5 and give-way road markings on the road surface. You need to give way to all drivers, so also and pedestrians on a zebra crossing.
2. Unmarked roundabouts.
These roundabouts do not have priority signs, so if you are using an unmarked roundabout you will get way over all the other drivers who want to use the roundabout.

When leaving a roundabout you need to follow the rules of turning off. This means that when you want to exit the roundabout, traffic continueing on the roundabout always has right of way.

- a. Techniques of watching the road if your driving straight ahead on a roundabout.
- b. Techniques of watching the road if your turning right on a roundabout.

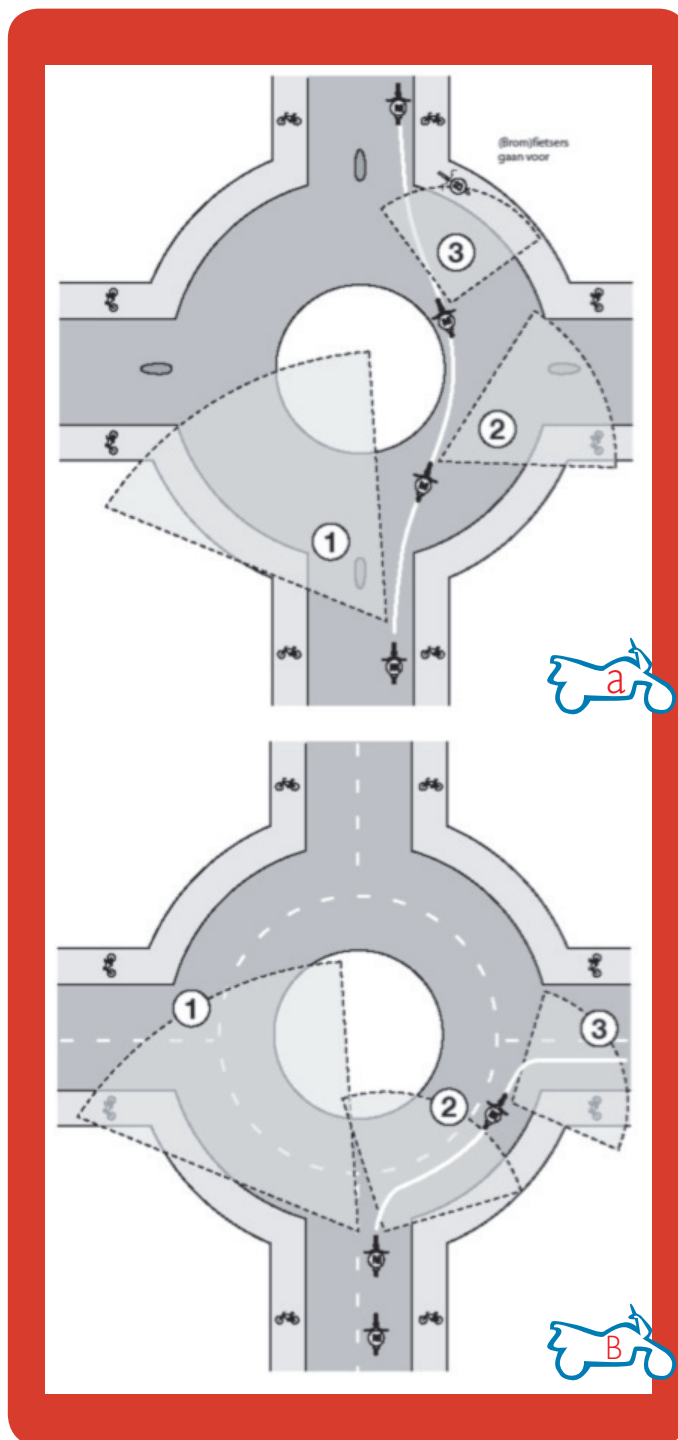

The advantage of a roundabout is that the speed with which you approach is lower when approaching a junction and that all drivers are approaching you from the left-hand side.

You use the traffic indicator as if you are approaching a junction. So before you make use of the roundabout, you turn on the right indicator if you want to go to the right. If you want to go left, you need to turn on the left indicator. If you want to go straight on you do not turn on the traffic indicator before making use of the roundabout, but when you want to exit the roundabout, you turn on the right indicator.

- a. The lane positioning is given by arrows on the road surface or by traffic signs
- b. Watching the road.

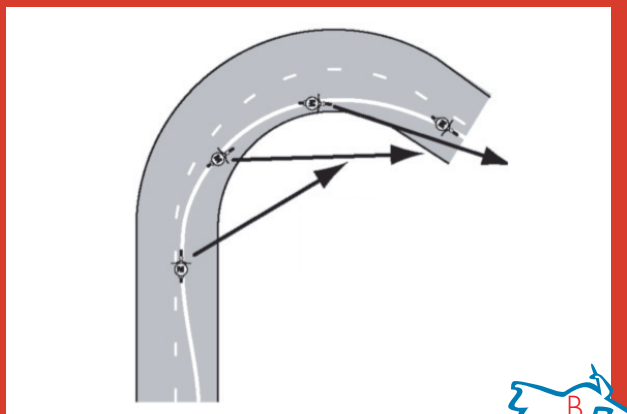
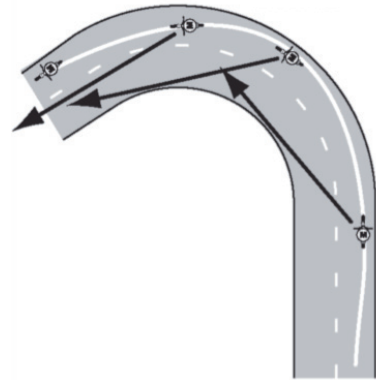

7. SPECIAL MANOEUVRES

Before you start to do the **special manoeuvres**, and during them, you need to give way to all other traffic. You are obliged to look. Look where the danger is coming from. This can be in front of you, but also behind you. To see what is happening behind you, you can use the mirrors. You're not an owl after all, and can not turn your head 180 degrees. This would be the best solution for us humans to drive a motor, because when you look in your mirrors; you miss a part next to the motor called the blind spot.

Special Manoeuvres are:

- Driving away (entering or leaving the traffic)
- Reversing in a straight line
- Driving into an entranceway
- Coming out of an exit
- Using an acceleration lane to join the traffic
- Deceleration lanes differ
- changing lanes (important)
- Turning around
- Overtaking an obstacle on your side of the road.

You need to switch on the traffic indicator briefly, before (the moment) you start with the actual manoeuvre. You need to switch off the traffic indicator after finishing the special manoeuvre.

Note:

Drivers who are entering or leaving the exit need to give right of way to all road users. You also need to give right of way to pedestrians who are walking on the exit. The picture (a) gives an example of that.



8. OVERTAKING

Always overtake on the left

Drivers need to overtake on the left-hand side and leave enough space for drivers who are overtaking.

Overtaking on the right is allowed:

1. Just before and on roundabouts
2. If you are driving in a queue / traffic jam, Motorcyclists are allowed to drive between the queues. If the motorriageway is divided into three lanes, the motorcyclist need to drive between the second and the third lane of the queue from the right. They are allowed to overtake a queue but only but only at a speed that is less than 10 km/h slower than the othertraffic. During this overtaking, the motorcyclist needs to use his hazard warning lights.
3. If you are driving on the right-hand of block markings.
4. If the vehicle you wish to overtake has moved left, turn left, and signals to the left.
5. If the vehicle you wish to overtake is a tram.
6. Cyclists and riders of motor-assisted bicycles are allowed to overtake other drivers on the right at all times.

Note: You may not overtake:

1. *Just before and on pedestrian crossings.*
2. *Next to the sign F1 (No overtaking)*
3. *If you wish to go left and need to cross a solid line which divides the road into lanes.*
4. *Just before level crossings, which are protected by flashing lights only.*
5. *Just before an indistinct bend (not official).*
6. *Just before an indistinct slope (not official).*
7. *Just before an unmarked junction (not official).*

9. BEING STATIONARY

There are two forms of stand still:

- Standing still **within** the traffic. For example to give way to others or before traffic lights.
- Standing still **outside** the traffic: For example to allow pedestrians to get in or out immediately or load or unload goods immediately

If you wish to stand still **outside** the traffic, it is called a special manoeuvre. You may not hinder other road users and always use your traffic indicator. If you wish to stand still you are supposed to stand still on the side of a motorriageway.

10. PARKING

As a motorcyclist, parking at a blue line, you do not have to lay down a parking disc.

It is **forbidden** to stand still:

1. On an **unmarked junction** or a **road crossings**.
2. On a **bicycle lane** marked with or without a solid line or on the road beside the bicycle lane.
3. On or within 5 metres of a **pedestrian crossing**.
4. At a **bus stop** along the entire length of the block marking. Without a block marking the same rule applies within 12 metres of the bus stop sign.
5. On the road next to a **bus lane** or a bus route
6. By a **yellow solid lane**.

11. TRUCK ROADS AND MOTORWAYS

Pedestrians are not allowed on truck roads and motorways. These roads may only be used on by motor vehicles that are able and allowed to drive at least:

Truck road : 50 km/h

Motorway : 60 km/h

The maximum speed on truck roads inside the built-up area is : 50 km/h.

Drivers are not allowed to reverse, make a U turn or stop on truck roads and motorways.

Vehicles longer than 7 metres or truck drivers are not allowed to use most left lane unless they want to change motorriageways.

a Truck road

b Mororway



11.1 Joining and exiting traffic

Joining the traffic

- On the motorway anticipate and look far ahead to find a space to join the traffic.
- Stay take right in the acceleration lane and accelerate in order to merge in with the traffic.
- Find a space to join the traffic; you need to know that when you merge in you must give way to drivers on the road. The drivers on the road have an average speed of 100 km/h. This means that you need to accelerate to 100 km/h on a truck road if you want to merge.
- If you want to merge, you need to use your mirrors and look to the side and over your shoulder.
- Always check everything again before you change lanes.

Exiting

- Turn your indicator approximately 300 metres before the exit.
- Before exiting the road, you need to use your mirrors and look over your right shoulder for/at the blind spot.
- Exit the road with the same speed, do not reduce your speed until you are on the deceleration lane so that the traffic behind you can drive on without having to reduce speed.
- Look far ahead to estimate the length of the deceleration lane and your speed.
- When you have moved onto the exit lane reduce your speed. Change your indicator to neutral once the block markings on your left have stopped.
- Judge early what kind of traffic situation you are in and reduce your speed accordingly.



12. LIGHTS

The purpose of driving with lights is not only to see but also to be seen well by others.

Lights are obligatory in the night and in tunnels. On a road concealed by low foliage other drivers may have difficulty seeing you coming.

Front:	Dipped headlights	Always
	Parking light	Never, Only to park your motor.
	Beam headlamp	Only at night, outside the built-up area if your dipped lights do not illuminate the road well enough, and if you do not inconvenience other road users.
	Fog light	Fog, Only use if there is fog or rain and you cannot see further than 200 metres.
Back:	Tail light	Always.
	Traffic indicator	While overtaking and spec. manoeuvres.
	Brake light	when using the brake pedal
	Licence plate light	Only in the evening when you use the dipped head lights and tail lights.
	Fog tail light	when you cannot see further than 50 metres.

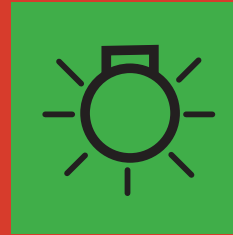

Parking light



Dipped headlights

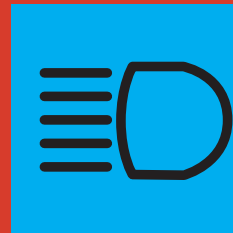

Beam headlamp



Fog light



Fog tail light

13. GENERAL POINTS OF ATTENTION

13.1 Road markings on the road surface

You are obligated to follow the direction of the arrow on the road surface; road markings stand above traffic rules in the hierarchy of importance. You are not allowed to cross a solid line on (your left). So you may cross a broken line. It is a normal situation, if the broken lines are small. If the broken lines are longer, you need to pay attention when you cross them. These tall broken lines are mostly used before and in a bend.

Block markings show that a road is diverging. The advantages of block markings are that you can already anticipate before you see the arrows. If you know that the lanes are splitting, you can already sort. A shape or a cross on the road surface means that you can not stand still, but you can use that road.

a en b The arrows on the road show how to sort before the roundabout

13.2 Pedestrian crossing

At a PC you must give way to all pedestrians and drivers of vehicles for disabled people who are crossing the zebra path or clearly just about to cross the PC. You are not allowed to park or stand still on a zebra crossing. Keep the zebra crossing clear.



13.3 Traffic lights

- A **red** light means you need to stop.
- If you are approaching an **amber** light and do not have the opportunity to stop the motor than proceed. Otherwise slow down and stop.
- A **green** light means you can proceed the way.

13.3 Bus stops

If the bus stop is **within the build-up area**, you must give way to the bus if it is indicating that it wants to pull away. This rule does not apply **outside the build-up area**.

13.4 Tunnel

Before entering the tunnel you need to turn your dipped headlights on.

Note: Most drivers often slow down when entering tunnel. They are afraid for the dark hole in the tunnel.

13.5 Seatbelts

Drivers of a motor vehicle and the passengers must always use of the seatbelts. Children who are smaller than 1.35 metres must make use of a suitable child restraint. Depending of the weight and the height of the child, this can be a baby motor seat, a child motor seat or a booster seat. The seats must meet the European standards and be provided with an ECE label or sticker. (Drivers and passengers who are smaller than 1.35 metres must make use of the three-point seat belts.)

13.6 Loads

- A load can not stick out more than 10 cm from the side of the vehicle.
- A load can not stick out more than 10 cm at the back of the motor or trailer.
- Loads may never stick out at the front of a trailer. At an accident, if you have to brake suddenly, the load on the trailer might shift forward.

13.7 Dike roads

On a dike road you will have normally have a good viewout the front, but you do not see any sidestreets. The road is normally small and they often have a special embarkment. The driver needs to drive in the middle of the road on a dike road.

13.8 Aquaplaning

Sometimes there can be two worn grooves in the length direction of the road. These places can be covered with water when it rains. When this happens, you can easily slide. This waterskiing on the road is called **aquaplaning**. If this is happens, you need to slow down slowly and drive straight ahead.

The tires have a **profile** too to prevent the driver from aquaplaing. The main grooves of the motor tires may not be less than 1 millimetres.

13.9 Danger of skidding

Everybody knows that the chance of icy roads is bigger with heavy snowfall. But icy roads can also occur when the temperature drops below 0. Also in the summer after long dryness, when it starts to rain, the road surface can be slippery. The meaning of skidding is a rotated movement of the tire that changes into a slippery movement. The chance of skidding is biggest if you change direction or change your speed. You always need to be calm with slipperiness and break in small doses in order to enter a situation slowly.

If you are skidding, you need to:

- Use the clutch so that that the tire will turn again.
- Steer directly in the skidding direction in order to let the tires rotate again. Look into the direction you want to go.
- Do not brake.
- You can brake if the situation is under control.

a A skidding motor



13.10 Facts

The talus poles on the right side of the road have a red reflectors; talus poles on the left side of the road have a white reflectors.

- You only can use the horn or light signal if there is a dangerous situation.
- a The talus poles
- b If you see this, it will propably be slippery. You need to pay attention to your speed!
- c While transporting dogs or sheep, the motor needs to have a partition to divide the driver's seat from the rest of the motor.

14. ENVIRONMENTAL ASPECTS

There is more fuel consumption:

- If the condition of a motor changes for exhample an open window causes 3% more fuel consumption, with a roof rack 10% or with the wrong tyres pressure 3%.
- Also the use of electricity influences the fuel consumption such as the radio 2%, lights 3%, air-conditioning 10% or heating 10%.

Leaving your engine running for longer than 1 minute while waiting is bad for the envoromant.



15. CRIME(S)

Death/gross bodily harm caused by negligence.

Road users are not allowed to behave in such a manner that a road accident is caused by them that resulted in the death or gross bodily harm of another person.

Prohibition to leave the scene of the accident.

Anyone involved in a road accident is not allowed to leave the scene of the accident, without reporting their personal details and license plate number of their motor vehicle. You need to give your details and your vehicles license plate number. Nor are you allowed to leave anyone behind in a helpless condition.

16. DANGEROUS SITUATIONS

Take a look at www.swov.nl

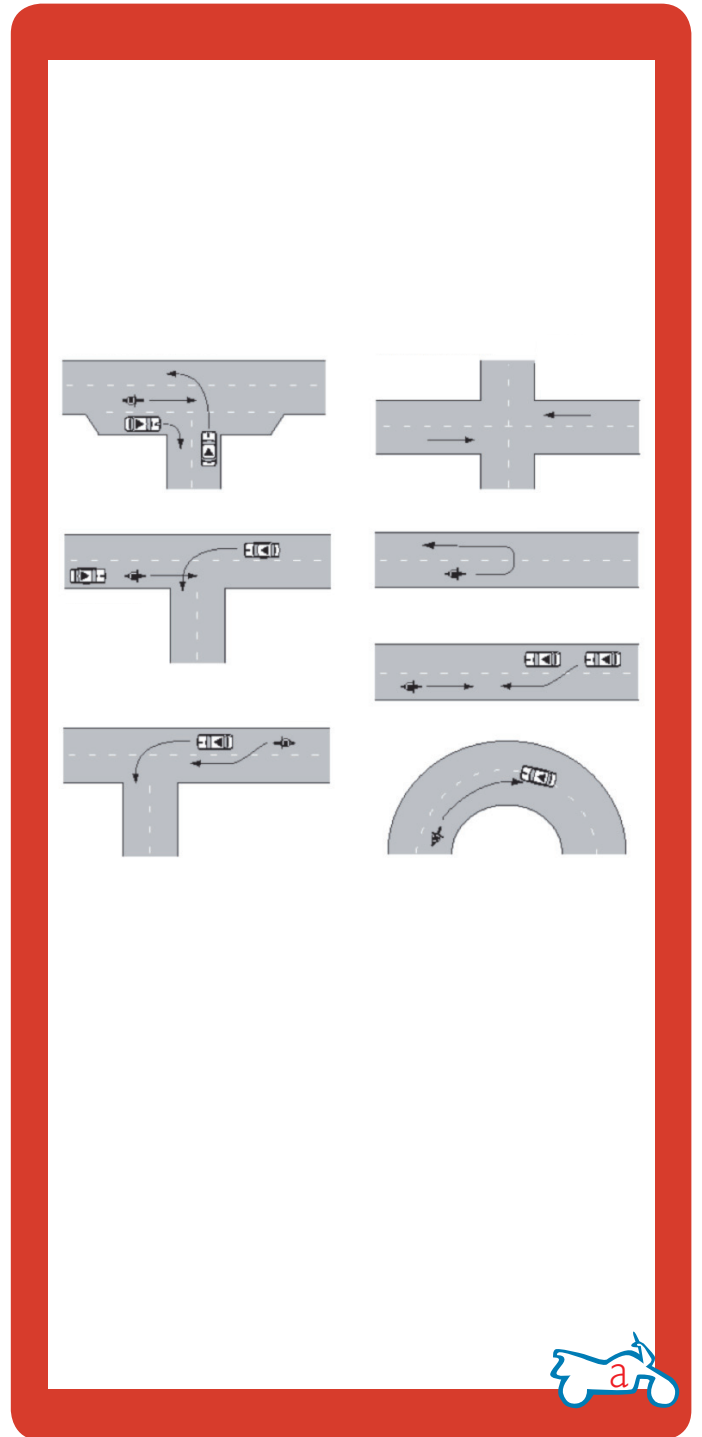

17. THE DUTCH TRAFFIC SIGNS



Speed limit



End of speed limit



Speed limit displayed on a display panel



Recommended speed



End of recommended speed

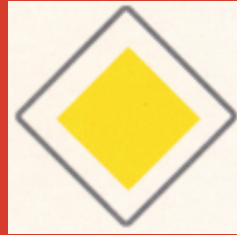

Priority road

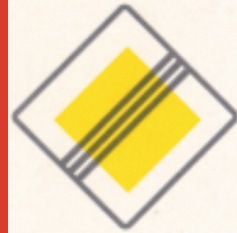

End of priority road



Crossroads with priority



Road junction with priority over minor road from the left



Road junction with priority over minor road from the right



Give priority to traffic on the main road ahead



Stop! Give priority to traffic on the main road ahead

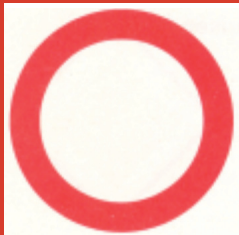

Road closed in both directions for vehicles, horse riders and people in charge of draught animals or cattle



No entry in this direction for vehicles, horse riders and people in charge of draught animals or cattle



One-way road



One-way road



Access permitted



No access for vehicles with more than two wheels



No access for goods vehicles



No access for motor vehicles with speeds less than 25 km/h



No access for horse riders, cattle, wagons, motor vehicles with speeds less than 25 km/h and micromotors, cyclists, riders of motor-assisted bicycles, mopeds and drivers or vehicles for disabled people



No access for motor vehicles towing trailers



No access for motorcyclists



No access for motor vehicles



No access for mopeds, motor-assisted bicycles and motor-powered vehicles for disabled people



No access for bicycles, motor-assisted bicycles and non-motor-powered vehicles for disabled people



No access for bicycles, motor-assisted bicycles, mopeds and vehicles for disabled people



No access for pedestrians



No access for vehicles and combinations of vehicles with a length, including the load, greater than indicated



No access for vehicles with a width, including the load, greater than indicated



No access for vehicles with a height, including the load, greater than indicated



No access for vehicles with an axle load greater than indicated



No access for vehicles and combinations of vehicles with a total weight greater than indicated



No access for vehicles motorrying hazardous substances



Rush-hour lane open



Clear rush-hour lane

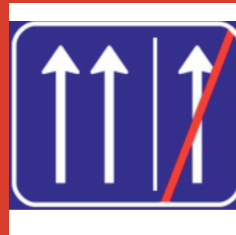

End of rush-hour lane



Roundabout, give way to vehicles on the immediate right



Instruction to all drivers to keep to right of the sign (or left if arrow is reversed)



This sign may be passed on either side



Instruction to drive ahead only



Instruction to follow the direction ahead shown by the arrow



Instruction to follow one of the directions ahead shown by the arrows



Instruction to follow one of the directions ahead shown by the arrows



No parking



No stopping



No parking bicycles and mopeds



Parking



Taxi rank



Parking for disabled drivers



Parking permitted for immediate loading and unloading of goods only



Parking facilities only for category of group vehicles shown



Parking for licence holders only



Entrance to controlled parking zone



Exit of controlled parking zone



Park and ride facilities



Parking facilities for motor shares



No overtaking



End of no overtaking zone



No overtaking of motors by lorries



End of zone with no overtaking of motors bby lorries



Give way to oncoming vehicles



Priority over oncoming vehicles



No U-turns



End of all restrictions imposed by traffic signs

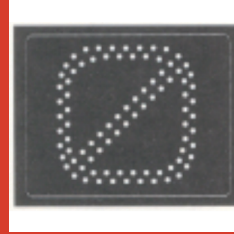

End of all restrictions imposed by electronic signalling panels



Stop! The sign may contain further information as to whom it is directed and why



Motorway



End of motorway



Trunk road



End of trunk road



Pedestrian priority area



End of pedestrian priority area



Footpath



End of footpath



Bridleway



End of bridleway



Route for pedal cycles only



End of pedal cycles route



Route for pedal cycles and mopeds only



End of route for pedal cycles and mopeds



Optional bicycle path



End of optional bicycle path



Built-up area



End of built-up area



Uneven road



Bend to right



Bend to left



Double bend, first to the right



Double bend, first to the left



Steep hill upward



Steep hill downward



Dangerous crossing



Roundabout

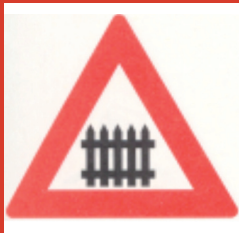

Level crossing with
barriers or gate ahead



Level crossing with
without barrier or gate
ahead



Level crossing with
single track



Level crossing with two
or more tracks

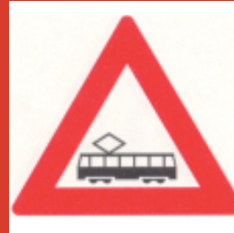

Tram crossing ahead



Opening or swing
bridge ahead



Road works ahead



Road narrows on both sides



Road narrows on the right side



Road narrows on the left side



Slippery road



School crossing



Pedestrian crossing



Pedestrians



Cyclists and moped riders



Loose chippings



Quayside or river bank



Wild animals



Cattle



Two way traffic



Low-flying aircraft



Side-winds



Traffic lights



Queuers likely



Dangers of accidents



Reduced visibility
because of snow, rain
or fog



Risk of ice or snow



Danger. Details of the danger are shown on the plate beneath



Speed bump



Low level motorway information sign showing both main and intermediary destinations and motorway number



Advance warning sign of a motorway showing the distance to the next exit (the top destination is the name of the exit), direction to aerodrome/airport and the road number



Information sign of exit to motorway service area, showing the name of the rest area and symbols for the services offered



High level motorway information sign showing lane instruction for through traffic and exit panel showing intermediary destinations, with the motorway number and European route numbers



Non-motorway advance information panel showing intermediary destinations, road numbers, a viaduct symbol and a sign for an industrial zone



Non-motorway information panels showing intermediary destinations and non-motorway road numbers



Signpost for cyclists and moped riders showing local and intermediary destinations, municipal cycle route numbers and showing intermediary destinations and intermediary cycle route numbers

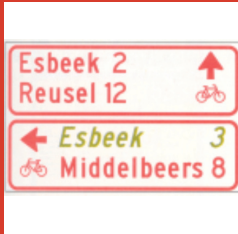

Signpost for cyclists and moped riders showing intermediary destinations and indicating an alternative route to one of the destinations



Diversion with alternative route shown on an advance warning panel for a non-motorway road

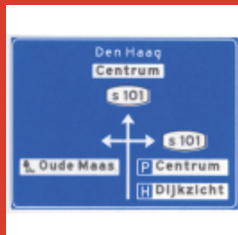

Advance warning panel within a built-up area, showing an intermediary destination, local destinations, local tourist sights, local facilities and road numbers though the town.



Lane instructions on a non-motorway road. Panel showing intermediary destinations, road numbers and directions to a motorway.



Local signpost within a built-up area showing names with individual districts



Signpost within a built-up area showing district numbers



Route for the conveyance of hazardous materials



No vehicle over height shown



Pedestrian crossing



Bus/tram stop



Get in lane



End of lane



Lane fork



Number of through lanes



No through road for vehicles



Advance warning of a no through road for vehicles



Advance warning of traffic information for the direction shown



Information on panel applies only to the lane indicated

17.1 Traffic Directions



General stop signals

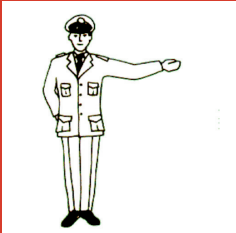

Stop signal for traffic approaching from the front

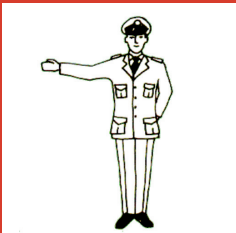

Stop signal for traffic approaching from behind

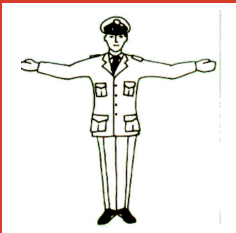

Stop signal for traffic approaching both from the front and behind



Stop signal for traffic approaching from the right

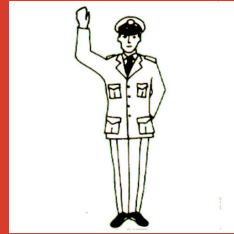

Stop signal for traffic in free-moving lanes. Traffic in other lanes to proceed with caution. Clear the junction.



Sign to reduce speed



Stop signal given by school crossing guard